

BOSTER COILS

CAPABILITIES OVERVIEW

Coilmaster's line of booster coils are designed for hot water or low-pressure steam heating.

Our pre-engineered 1 and 2 row coils allow us to offer exceptional value and lead times for this product. One day to one week availability insures that we meet any requirement for these coils.

<http://coilmastercorp.com/coil-capabilities-overview/booster-coils/>

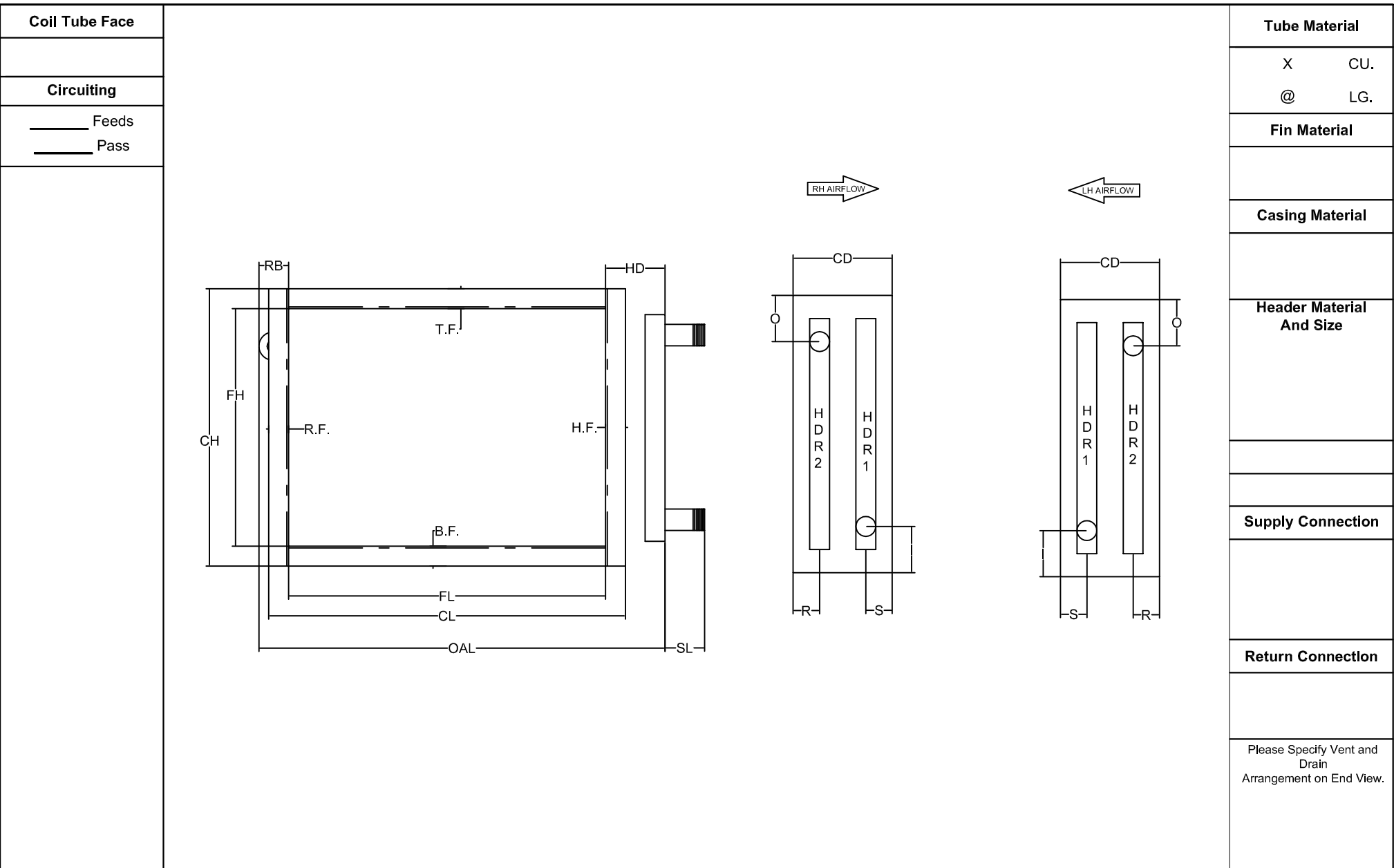

ROWS	FPI	FH	FL	CH	CL	CD	HD	OAL	SL	X	I	S	O	R	T.F.	B.F.	H.F.	R.F.	R.B.

NOTES:	TAG COIL:	W.O.	Tube Supports Recommended For Coils Over 50.00" Long. All coils are tested with 550 p.s.i. Dry Nitrogen
		ITEM	
		QTY.	
		REV	
		MODEL #	